



# Connection Impact Assessment (CIA) Application

Tillsonburg Hydro Inc. | Hydro Operations | hydrops@tillsonburg.ca | 519-688-3009



## ▶ ABOUT THIS FORM

This Connection Impact Assessment (CIA) application is to be completed by any proponent interested in connecting a Distributed Energy Resources (DER) with a project size over 10 kilowatts (kW) to Tillsonburg Hydro Inc. This includes DER applying for a new CIA or for revision(s) to their original CIA. This form expresses an intent to enter into an agreement between Tillsonburg Hydro Inc and the customer (or host customer\* for load displacement projects) for completion of a CIA associated with connecting a DER to the Tillsonburg Hydro Inc distribution grid. The CIA Application shall be part of the required servicing (electrical installation, maintenance, and operating) agreements between Tillsonburg Hydro Inc and the proponent. Through this process, Tillsonburg Hydro Inc. will be the proponent's contact with the transmission system provider (e.g. Hydro One Networks Inc.) and, if necessary, the provincial market operator, namely, the Independent Electricity System Operator (IESO).

\*For Load Displacement projects, the term "host customer" refers to the owner of the load facility. The term "DER owner" refers to the owner of the DER facility.

Emergency Backup Generators should use the Emergency Backup Generation Application Form available at: [www.tillsonburghydro.ca](http://www.tillsonburghydro.ca)

## ▶ TECHNICAL REQUIREMENTS

For technical requirements of Tillsonburg Hydro Inc.'s DER projects, refer to the "DER Technical Interconnection Requirements Interconnections at Voltages 50kV and Below", available at: [www.tillsonburghydro.ca](http://www.tillsonburghydro.ca)

## ▶ SUBMISSION INSTRUCTIONS

Please return the completed form, fees and other required documents by mail to:

Tillsonburg Hydro Inc.  
10 Lisgar Ave.  
Tillsonburg, Ontario, N4G 5A5  
Attn: DER CONNECTIONS

## IMPORTANT NOTES

- ▶ - An engineering stamp and all red box fields (on electronic version of form) are mandatory. Incomplete applications may be returned by Tillsonburg Hydro Inc. and will result in delays in processing your application. Click the "Validate Form" button on the top right of this page to ensure all required information is filled. If any of the required fields are not applicable to your project, type "N/A" in any required text field or "0" in any required numerical field
- Tillsonburg Hydro Inc. specific requirements and notes are found in Sections S and T, respectively
- Applicants are cautioned NOT to incur major expenses until Tillsonburg Hydro Inc. approves to connect the proposed DER facility.
- All technical submissions (CIA Application, Single Line Diagrams, etc.) must be signed, dated and sealed by a licensed Ontario Professional Engineer (P.Eng.).
- The proponent will pay for the CIA according to the Tillsonburg Hydro Inc. CIA Fee Schedule.





- The siting restrictions in O. Reg. 274/18 which were administered by electricity distributors such as Tillsonburg Hydro Inc. have been replaced by amendments to the Planning Act (Ontario) that puts siting and planning requirements for renewable DER facilities under municipal oversight. It is recommended that you discuss municipal permitting and approvals requirements with the planning department in the municipality where your DER project is located before you proceed.

**SECTION A: APPLICATION INFORMATION**

Engineering Stamp <input type="text"/>	Application Type <i>choose one</i>	Date <i>mm/dd/yyyy</i>
	<input type="text"/>	<input type="text"/>
	Program Type/Purpose <i>choose one</i>	Program Type (additional details)
	<input type="text"/>	<input type="text"/>
Project Name		
<input type="text"/>		
IESO Contract Number <i>F-XXXXXX-XXX-XXX-XXX</i>	IESO Reference Number <i>FIT-XXXXXXX</i>	
<input type="text"/>	<input type="text"/>	

Ontario Corporate Number or Business Identification Number	Proposed In Service Date <i>mm/dd/yyyy</i>
<input type="text"/>	<input type="text"/>

*If this project is a subdivision project, please complete the following fields:*

Subdivision Project Name	Number of Lots
<input type="text"/>	<input type="text"/>

*For certain application type selections, please complete the required fields:*

Original CIA Project ID # *xx,xxx*

Revised Fields *list the fields that have changed from your previous application*

**SECTION B: PROJECT LOCATION**

Address	
<input type="text"/>	
City / Town / Township	Postal Code
<input type="text"/>	<input type="text"/>
Lot Number(s)	Concession Number(s)
<input type="text"/>	<input type="text"/>





### ▶ SECTION C: CONTACT INFORMATION

CIA will be issued in the name of the host customer (load facility owner). All agreements (including CCA and DCA) are only made between Tillsonburg Hydro Inc. and the host customer. This section is strictly to gather contact information of some of the key contacts that are involved with the project.

Who is the single point of contact for this project?

Host Customer      DER Owner (if different from host customer)      Consultant

Please enter the following information about the **host customer** (load facility owner)

Contact Person

Company's Legal Name

Mailing Address *including postal code, P.O. Boxes and Rural Routes will not be accepted*

Work Telephone

Cell Phone

Fax Number

Email Address

Please enter the following information about the **DER owner** (if different from host customer)

Contact Person

Company's Legal Name

Mailing Address *including postal code, P.O. Boxes and Rural Routes will not be accepted*

Work Telephone

Cell Phone

Fax Number

Email Address

Please enter the following information about the **consultant**

Contact Person

Company's Legal Name

Mailing Address *including postal code, P.O. Boxes and Rural Routes will not be accepted*

Work Telephone

Cell Phone

Fax Number

Email Address





## ▶ SECTION D: CUSTOMER STATUS

Is there an existing Tillsonburg Hydro Inc. account at the project location?

Yes No

Is the account holder aware of this application?

Yes No

Does your account fall within a residential-rate classification?

Yes No  Do not Know

Existing Account Number

Account Holder Name

Does the account holder have an HST registration number?

Yes No

HST Number

## ▶ SECTION E: EXISTING DER

Are there existing DER at the point of common coupling (PCC)?

Yes No

Existing Project Number

Existing Project Size (kW)

Program Type For Existing DER *choose one*

DER type: Synchronous Induction Inverter based Other

For synchronous units	For induction units	For inverter based units
Min. power limit for stable operation <i>kW</i> <input type="text"/>	Direct axis sub-transient reactance, $X''_d$ <i>pu</i> <input type="text"/>	Inverter rating <i>kVA</i> <input type="text"/>
Direct axis sub-transient reactance, $X''_d$ <i>pu</i> <input type="text"/>	Direct axis transient reactance, $X'_d$ <i>pu</i> <input type="text"/>	Maximum continuous power output <i>kW</i> <input type="text"/>
Direct axis transient reactance, $X'_d$ <i>pu</i> <input type="text"/>	Total PF correction installed <i>kVAR</i> <input type="text"/>	
Direct axis synchronous reactance, $X_d$ <i>pu</i> <input type="text"/>		
Zero sequence reactance, $X_0$ <i>pu</i> <input type="text"/>		





## ▶ SECTION F: PROJECT INFORMATION

Station Name *(optional to leave blank for behind the meter projects)*

Fuel/Energy Type *select all that apply*

Feeder *(optional to leave blank for behind the meter projects)*

Feeder Voltage (kV) *(optional to leave blank for behind the meter projects)*

Project Size (kW) *total maximum output capacity*

Equipment Capacity (kVA) *total equipment nameplate rating*

Type of Connection

Single Phase

Three Phase

*If this is a solar project, please answer the following questions:*

Mounting Type *select one*

*If this is a water project, please answer the following questions:*

Is your generation facility located on provincial Crown or federally-regulated lands?

Yes

No

Is water your primary energy source?

Yes

No

## ▶ SECTION G: STATION SERVICE LOAD INFORMATION

**The host customer's station service load details**

*If there is an existing account at the project location, populating the fields in Section G is required for Tillsonburg Hydro Inc.. Ensure selection below matches with this note.*

Required

Optional

Maximum Demand of Station Service Load of DER *kW*

Average Monthly Consumption *kWh*





## ▶ SECTION H: CONNECTION INFORMATION

On a cut-out from the Tillsonburg Hydro Inc. DOM (Distribution Operating Map), or a site plan if a DOM is not made available by the LDC, provide the location of the generation facility with proposed line routings for connection to Tillsonburg Hydro Inc.'s distribution system. It should identify the Point of Expansion (POE), the Point of Common Coupling (PCC), the location of the generation facility, and (if applicable) the route of the new line between the generation facility and the POE (ie. on private property or public road/right-of-way). This is not required for existing load customers that are connecting a load displacement generation, net metering generation or energy storage system behind their existing metered connection point. Please see "Appendix A" for a visual representation of POE and PCC.

DOM Drawing/Sketch Number

DOM Revision Number

Please provide an SLD of the Generator's facilities, including the PCC, transformer and connecting station, feeder, and supply voltage.

SLD Drawing/Sketch Number

SLD Revision Number

POE Latitude *degree decimal format*

POE Longitude *degree decimal format*

PCC Latitude *degree decimal format*

PCC Longitude *degree decimal format*

Generation Facility Latitude *degree decimal format*

Generation Facility Longitude *degree decimal format*

Length of Line from POE to PCC *km*

Length of Line from PCC to Generation Facility *km*

*Important: The line between the PCC and the Generation Facility must NOT be shared with any other DER owner (refer to Appendix A).*

Conductor Type/Size *for the line between the PCC and the Generation Facility*

Generator Fault Contribution *with fault location at the PCC*

### IMPORTANT NOTES:

If this project requires line expansion work between the POE and PCC, Tillsonburg Hydro Inc. will provide a cost estimate to construct any line located on public road right-of-way. The cost estimate will include a breakdown of uncontestable work (i.e. overbuild to existing line) that can only be performed by Tillsonburg Hydro Inc., as well as contestable work (i.e. new construction/green-field) that may be performed by the Generator, their contractor or Tillsonburg Hydro Inc.. The design of uncontestable and contestable work shall conform to Tillsonburg Hydro Inc. specifications).

For Generator-owned line, the Generator may apply to construct the line on existing Tillsonburg Hydro Inc.-owned poles. This is known as an application for Joint Use (JU) of poles. If the application is accepted, Tillsonburg Hydro Inc. will provide the Generator with information on initial connection costs, annual pole-space rental and emergency service (ES) fees, and required JU & ES Agreements.





### ▶ SECTION I: ENERGY STORAGE OR UPS

Please complete the following section if your project includes energy storage.

Number of Units

Inverter Unit Size enter zero if inverter is shared with generation unit(s)

Energy Storage Unit Size kWh

Total Energy Storage Size kWh

Energy Storage Facility Control Strategy

Peak Shaving

Dynamic VAR Support

Frequency Support

Other

Please submit a detailed description of the control strategy according to the templates in Appendix B. Tillsonburg Hydro Inc. reserves the right to modify the control strategy as part of its Detailed Technical Connection Assessment.

### ▶ SECTION J: LOAD DISPLACEMENT/PEAK SHAVING

Please complete the following section if this is a load displacement or peak shaving project

Operating Mode

Parallel

Non-Parallel

Transition Type

Closed "make before break"

Open "break before make"

Time that generator remains parallel to grid closed transition only, ms

For non-parallel load displacement, SCADA monitoring and Gross Load Billing (GLB) may apply. For load displacement generation facilities, please attach a schedule of the forecasted maximum generation output (as a function of loading of the facility). At a minimum, include the forecasted generation output information (i.e. Watts and VARs) during the minimum and maximum of the load facility to which the load displacement generator is connecting (see Appendix C for template)





### SECTION K: DER CHARACTERISTICS

For facilities with multiple generators: If your generators have different characteristics, please use the "Add Page" button and provide the characteristics for each generator on the additional pages.

DER type: Synchronous Induction Inverter based Other

Number of Generating Units  Rated Capacity of Each Unit  kW  kVA DER Output Voltage  in kV

Manufacturer  Type or Model Number

If Power Conversion Type is "Other", please provide values equivalent to a Synchronous or Induction type generator.

Maximum Starting In-rush Current  multiple of full load current, pu Generator Winding Connection Delta Star

Neutral Grounding Method  for star winding connection only Impedance R  in ohms Impedance X  in ohms

Limits of range of reactive power at the machine output:

Lagging  over-excited, kVAR Lagging Power Factor  Leading  under-excited, kVAR Leading Power Factor

Limits of range of reactive power at the PCC:

Lagging  over-excited, kVAR Lagging Power Factor  Leading  under-excited, kVAR Leading Power Factor

For synchronous units	For induction units
Nominal Machine Voltage <input type="text"/> kV (LL)	Nominal Machine Voltage <input type="text"/> kV (LL)
Unsaturated Reactance <input type="text"/> kVA Base	Unsaturated Reactance <input type="text"/> kVA Base
Unsaturated Reactance <input type="text"/> kV Base	Unsaturated Reactance <input type="text"/> kV Base
Direct Axis Subtransient Reactance, Xd'' <input type="text"/> pu	Direct Axis Subtransient Reactance, Xd'' <input type="text"/> pu
Direct Axis Transient Reactance, Xd' <input type="text"/> pu	
Direct Axis Synchronous Reactance, Xd <input type="text"/> pu	
Subtransient Time, Td'' <input type="text"/> ms	
Zero Sequence Reactance, X0 <input type="text"/> pu	







## SECTION L: INTERFACE TRANSFORMER

The transformer connecting to the Tillsonburg Hydro Inc. distribution system

Transformer Ownership  
Customer THI

Transformer Rating *kVA*

Transformer Type

Single Phase Three Phase

Nominal Voltage of High Voltage Winding *kV*

Nominal Voltage of Low Voltage Winding *kV*

Impedance Base (if different than ratings above)

 kVA Base  kV Base

Impedance (R) *pu* Impedance (X) *pu* Impedance (Z%) %

 OR 

High Voltage Winding Connection

Delta Star

High Voltage Grounding Method *for star winding connection only*

Solid Ungrounded Impedance

Star Impedance R *in ohms*

Star Impedance X *in ohms*

Low Voltage Winding Connection

Delta Star

Low Voltage Grounding Method *for star winding connection only*

Solid Ungrounded Impedance

Star Impedance R *in ohms*

Star Impedance X *in ohms*

### Notes

The term "High Voltage" refers to the connection voltage to Tillsonburg Hydro Inc.'s distribution system and "Low Voltage" refers to the generation or any other intermediate voltage.

Providing a photo of transformer equipment along with this application may help expedite your application.





### SECTION M: INTERMEDIATE TRANSFORMER

#### Transformer between the interface transformer and DER

Please complete the following section if your project includes an intermediate transformer.

Do you intend to install an intermediate transformer?

Yes No

Transformer Rating *kVA*

Transformer Type

Single Phase Three Phase

Nominal Voltage of High Voltage Winding *kV*

Nominal Voltage of Low Voltage Winding *kV*

Impedance

kVA Base

kV Base

Impedance R *pu*

Impedance X *pu*

High Voltage Winding Connection

Delta Star

High Voltage Grounding Method *for star winding connection only*

Solid Ungrounded Impedance

Star Impedance R *in ohms*

Star Impedance X *in ohms*

Low Voltage Winding Connection

Delta Star

Low Voltage Grounding Method *for star winding connection only*

Solid Ungrounded Impedance

Star Impedance R *in ohms*

Star Impedance X *in ohms*

Notes:

The term "High Voltage" refers to the connection voltage to Tillsonburg Hydro Inc.'s distribution system and "Low Voltage" refers to the generation or any other intermediate voltage.

### SECTION N: HIGH-VOLTAGE GROUNDING TRANSFORMER

Please complete the following section if your project includes a high-voltage grounding transformer.

Do you have a high-voltage grounding transformer?

Yes No

Transformer Type *select one*

Zig-Zag Star-Delta

Zero Sequence Impedance (Z0) R *ohms*

Zero Sequence Impedance (Z0) X *ohms*





### ▶ SECTION O: SUBMISSION CHECKLIST

Please ensure the following items are completed prior to submission. Your application may not be processed if any part is omitted or incomplete:

- Payment in full including applicable taxes (by cheque payable to "Tillsonburg Hydro Inc.")
- Completed Form B stamped by a Professional Engineer
- Signed Study Agreement (original signature is required)
- Single Line Diagram (SLD) of the Generator's facilities, must be stamped by a Professional Engineer
- Protection Philosophy
- Distribution Operating Map (DOM) and/or Site Plan *(not required for existing load customers that are connecting a load displacement generation, net metering generation or energy storage system behind their existing metered connection point)*
- Load Displacement Generation Facility's load and generation schedules (if applicable)
- Load Displacement Generation Facility's mode of operation (if applicable)
- Energy Storage Facility operating strategy description an parameters (if applicable)
- Emergency Backup Generation Facility's mode of operation (if applicable)

### ▶ SECTION P: CIA APPLICATION FEE CHECKLIST

Please ensure the following items are completed prior to submission. Your application will not be processed if any part is omitted or incomplete. Check all that apply:

- Applicable CIA Fee**  
See the [Connection Impact Assessment Fee Schedule](#) on our website for costs. Please enter the amount from the fee schedule.      \$  +HST
- Transmission Customer Impact Assessment (TxCIA) Fee (if applicable)**  
A TxCIA is also required if the total nameplate generation of the project is greater than 10MW.      \$  +HST
- IESO System Impact Assessment (SIA) Fee (if applicable)**  
An SIA deposit is required if the total nameplate generation of the project is greater than 10MW. The total cost of the SIA will be Trued Up/Down upon the receipt of the SIA from the IESO. See the [IESO's SIA Application](#) for costs.      \$





**SECTION Q: ATTACHMENTS**

*Attached Documents / Drawings*

Item #	Description	Document #	# of Pages

**SECTION R: NOTES**

SAMPLE





▶ **SECTION S: Tillsonburg Hydro Inc. Specific Required Fields**

*This section contains specific information that is required by Tillsonburg Hydro Inc.. Please read Section T notes regarding this section if you need further details.*

What is the barcode of the nearest pole serving the project location?

Tillsonburg Hydro Inc. Account Number *if transformer is owned by Tillsonburg Hydro Inc.*

▶ **SECTION T: Tillsonburg Hydro Inc. Specific Additional Notes**

**Section A:** no additional notes

**Section B:** no additional notes

**Section C:** no additional notes

**Section D:** no additional notes

**Section E:** no additional notes

**Section F:** no additional notes

**Section G:** no additional notes

**Section H:** Tillsonburg Hydro Inc. will prepare the Distribution Operating Map upon receipt of the CIA Application

**Section I:** no additional notes

**Section J:** no additional notes

**Section K:** no additional notes

**Section L:** Refer to Tillsonburg Hydro Inc.'s Conditions of Service supply details

**Section M:** no additional notes

**Section N:** no additional notes

**Section O:** The Distribution Operating Map (DOM) is not required to accompany the CIA Application. A Site Plan is required as part of the CIA Application. A Study Agreement is not required by THI.

**Section P:** does not apply

**Section Q:** no additional notes

**Section R:** no additional notes

**Section S:** - For question: "What is the barcode of the nearest pole serving the project location?", this is only applicable if you choose "No" to question: "Is there an existing Tillsonburg Hydro Inc. account at the project location?" in Section D

- For question: "Tillsonburg Hydro Inc. Account Number (if transformer is owned by Tillsonburg Hydro Inc. )", this is only applicable if you answer "Tillsonburg Hydro Inc." to question: "Transformer Ownership" in Section L.





## ▶ APPENDIX A - FIGURES & DIAGRAMS

### Figure A1: Where There is No New Tillsonburg Hydro Inc. Owned Line Expansion

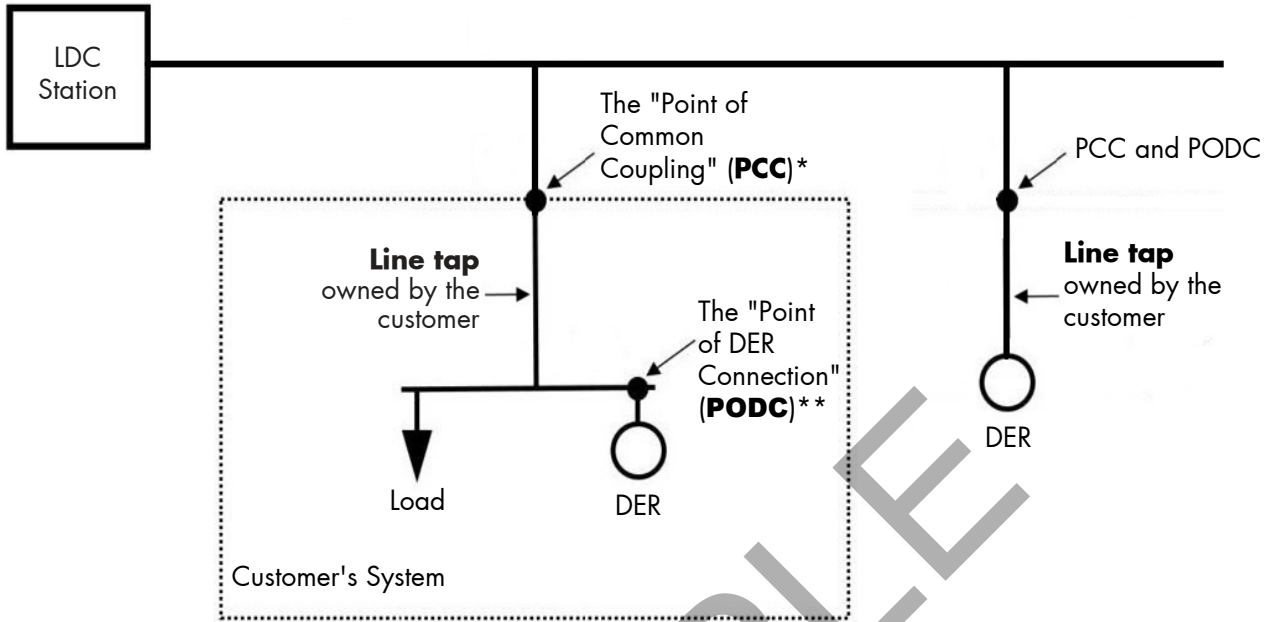

\*PCC: the point where the customer facility connects to the LDC owned system

\*\*PODC: the point where the DER unit(s)'s interconnection system connects the DER unit(s) to the DER facility.

### Figure A2: Where There is a New Tillsonburg Hydro Inc. Owned Line Expansion

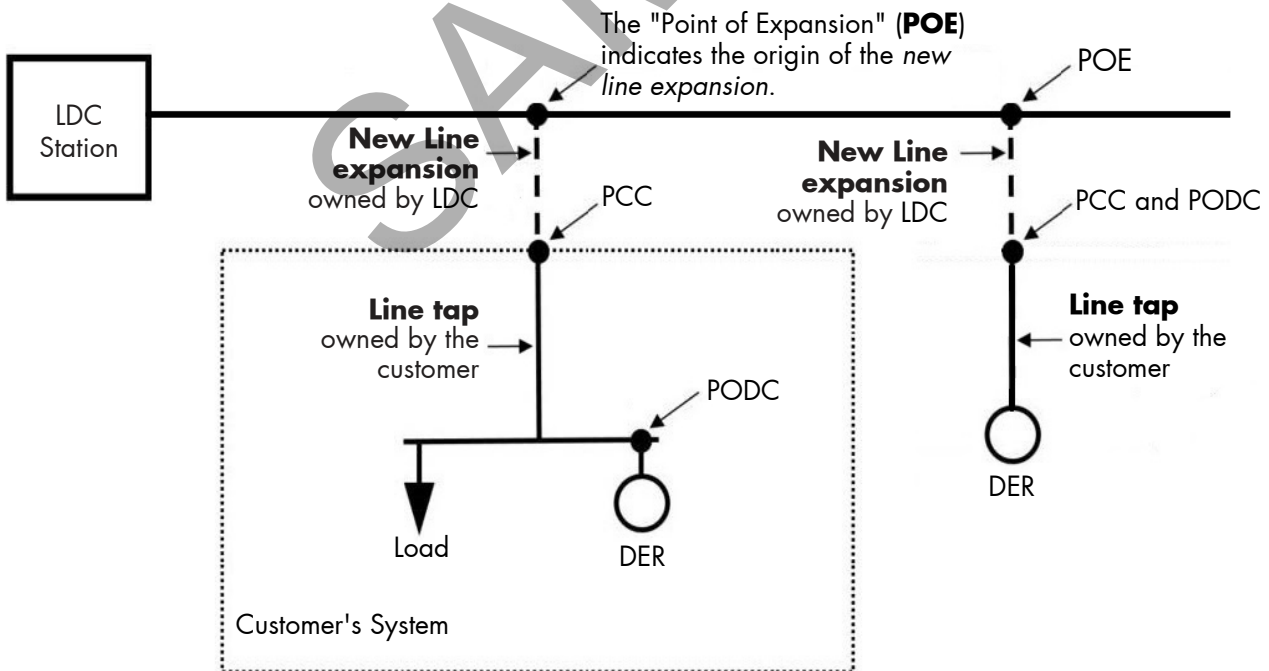



## ▶ APPENDIX B - MINIMUM CONTROL STRATEGY INFORMATION FOR ENERGY STORAGE FACILITIES OR OTHER TECHNOLOGIES

**Figure B1: Peak Shaving**

Peak Shaving			
Description of Control Strategy			
When Operating as a Load			
Switch In Time	Switch Out Time	Load kW (peak)	Load kVAR (peak, leading/lagging)
When Operating as a Generator			
Switch In Time	Switch Out Time	Generation kW (peak)	Generation kVAR (peak, leading/lagging)

**Figure B2: Dynamic VAR Support**

Dynamic VAR Support			
Description of Control Strategy			
Switch In Condition	Switch Out Condition	Generation kW (peak)	Generation kVAR (peak, leading/lagging)

**Figure B3: Frequency Support**

Frequency Support			
Description of Control Strategy			
Switch In Condition	Switch Out Condition	Generation kW (peak)	Generation kVAR (peak, leading/lagging)

**Figure B4: Other Control Strategies**

Other	
Description of Control Strategy and Relevant Operating Parameters	





## ▶ APPENDIX C - LOAD DISPLACEMENT FIGURES

**Figure C1: Example Schedule With Minimum Information Required for Load Displacement Projects**

	Load of Facility (kW)	Load of Facility (kVAR, lead or lag)	Generation Output (kW)	Generation Output (kVAR, lead or lag)
Minimum Load				
Maximum Load				

SAMPLE

